



- Simplified user interface
- Robust & compact design
- Perfect visibility with slidable seats
- High efficiency drive train
- High maneuverability

TECHNICAL DATA

MASSES

Mass (incl. standard screed) 10.3 t

DIMENSIONS

Basic width 1.80 m
 Working width, hydraulic extendable 3.50 m
 Working width, maximum (incl. extension boxes) 4.70 m
 Working width, minimum (with reducing shoe) 0.70 m
 Front ramp angle 15°
 Rear ramp angle 13°

CAPACITY

Placement thickness, min/max -120 /200 mm
 Theoretical placement capacity 350 t/h

MATERIAL HOPPER

Capacity 10.5 t
 Hopper width, internal 3040 mm
 Dumping height, center 520 mm

OPERATION

Operational controls Conventional
 Platform Extendable roof, slidable seat station, sliding/tilting control panel, swivel seat

TRACTION

Maximum paving speed 25 m/min
 Transport speed 15 km/h

ENGINE

Manufacturer/Model Deutz TD 2.9 L4
 Emissions according to Stage V /Tier 3
 Rated power 55.4 kw /54 kw @2200 rpm
 Electrical system 24 V
 Fuel tank capacity 86 l

UNDERCARRIAGE

Final drive Hydrostatic
 Front wheels 492/260-378
 Rear wheels 385/65-R22,5
 Turning radius (inside) 2.51 m
 Turning radius (outside) 4.31 m

CONVEYOR

Conveyor control Proportional speed control, Both sides driven independently, Reversible
 Conveyor type Dual bar feeder
 Conveyor width 700 mm

AUGER

Auger control Proportional speed control, Both side driven independently
 Auger diameter 320 mm
 Auger height adjustment 200 mm

Find us locally at www.dynapac.com

We reserve the right to change specifications without notice. Photos and illustrations do not always show standard versions of machines. The above information is a general description only, all informations are supplied without liability.



- Simplified user interface
- Robust & compact design
- Perfect visibility with slidable seats
- High efficiency drive train
- High maneuverability

DIMENSIONS

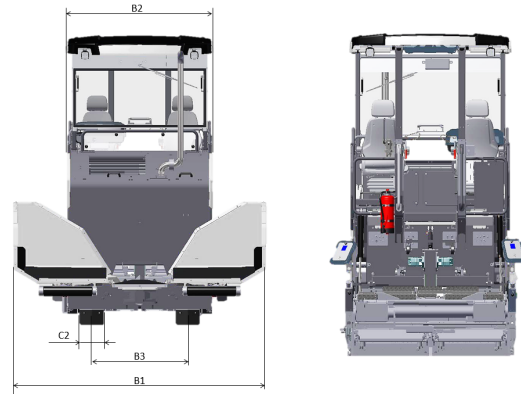
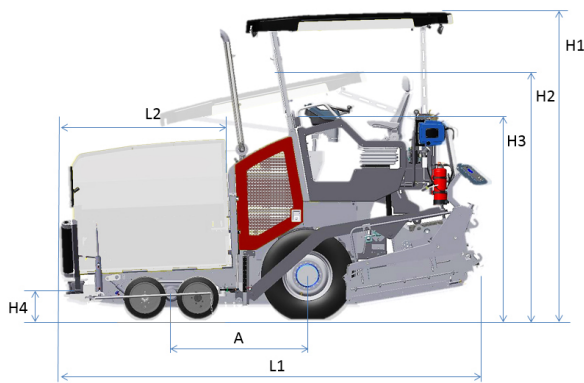

DIMENSIONS

A. Wheelbase	1.60 m
B1. Width, max.	3.15 m
B2. Width, standard	1.80 m
B3. Width, center of wheels	1.45 m
H1. Height, max.	3.60 m
H2. Height, transport	2.92 m
H3. Height	2.40 m
H4. Dumping height	0.50 m
L1. Length	4.99 m
L2. Length, hopper	1.99 m

Find us locally at www.dynapac.com

We reserve the right to change specifications without notice. Photos and illustrations do not always show standard versions of machines. The above information is a general description only, all informations are supplied without liability.

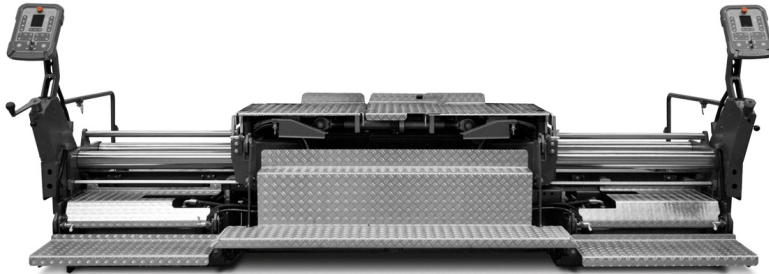

COMPATIBLE SCREEDS

V3500 V / V E / TV / TV E

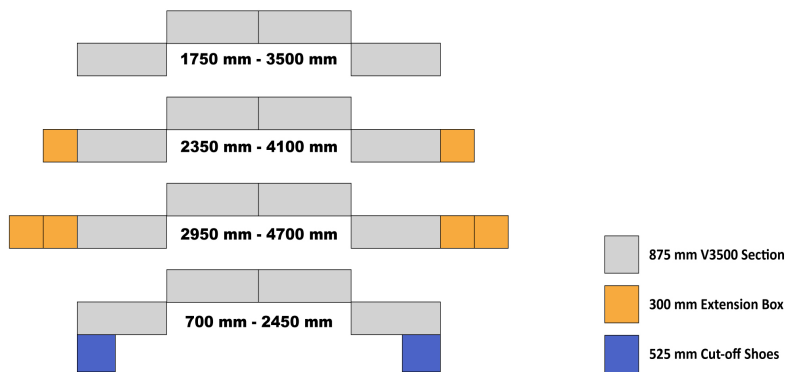

Find us locally at www.dynapac.com

We reserve the right to change specifications without notice. Photos and illustrations do not always show standard versions of machines. The above information is a general description only, all informations are supplied without liability.