







Dynapac F1250CS

Compact pavers





Características técnicas

 Massa	
Peso (incl. mesa)	7,0 t
 Dimensões	
Largura básica	1,20 m
Largura de trabalho, máxima	3,50 m
Largura de trabalho, com extensão hidráulica	2,40 m
Largura de trabalho, mín. (com sapata de redução)	0,30 m
Ângulo de carregamento (rampa)	14°
 Capacidade	
Paving thickness (max/min)	200 /-150 mm
Produção teórica	300 m ³ /h
 Trem de transmissão	
Comprimento	1.390 mm
Largura das sapatas	200 mm
Transmissão	Transmissões de acionamento direto
 Tração	
Velocidade de pavimentação	up to 27 m/min
Velocidade de transporte	0,9 m/s
 Operação	
Painel de operação	Slidable left/right
Platform	Extendable platform

 Motor	
Fabricante/Modelo	Deutz TD2.9 L4
Emissões	Tier 3/Tier 4
Potência nominal	54 kW (72 hp) @ 2200 rpm
Sistema elétrico	2 x 24V, 72 Ah
Tanque de combustível	85 litros

 Silo de material	
Capacidade	2.5 m ³ (5.5 t)
Altura de descarga, centro	570 mm
Largura interna	2.830 mm

 Transportador	
Tipo	Splitted conveyor drive with center cover
Largura	620 mm
Controle	Automatic with limit switches

 Sem-fim	
Diâmetro	320 mm
Controle	Automatic with ultrasonic sensor
Auger ajuste de altura	Infinitely variable by 150 mm

Verifique o seu distribuidor local em nosso site www.dynapac.com.br

As informações acima se referem a uma descrição geral somente, não contém nenhum tipo de garantia. A Dynapac reserva-se o direito de alterar especificações sem prévio aviso. Fotos e ilustrações deste folheto podem conter itens opcionais.

Dynapac F1250CS

Compact pavers



Características técnicas

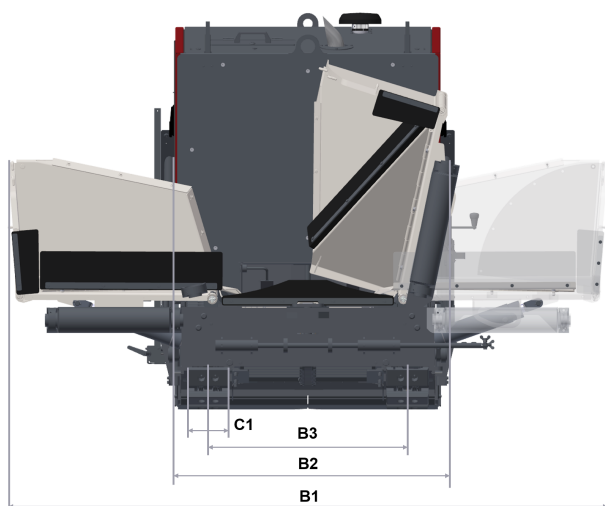
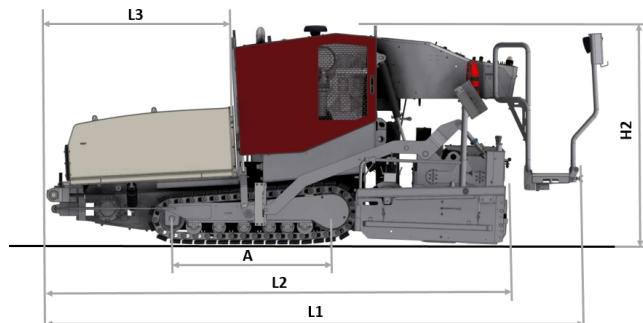

Dimensões	
A. Axle track	1390 mm
B1. Width, max.	2820 mm
B2. Width, standard	1430 mm
B3. Largura, entre esteiras	940 mm
C1. Largura da sapata	200
H2. Altura, transporte	2020 mm
L1. Length, total	4760 mm
L2. Comprimento, transporte	4450 mm
L3. Comprimento, silo	1640 mm



Equipamentos standard

2 front & 2 rear lights, Conventional electrics, Conveyor reversible (splitted), Dashboard with toggle switches, Eco Mode, Extendable steps operator platform, Hopper hydraulic separate control, Mechanical auger height adjustm., Mechanical conveyor limit switches, Ultrasonic sensors auger



Opcionais

Back-up alarm, Cut off shoes (250mm or 350mm), Emulsion spray equipment (Gloria), Emulsion spray equipment, pump, hose dispenser, Fire extinguisher, First aid kit, Foldable material guide plates, LED lights, Light for auger compartment, Material laying kit (left or right), Panolin bio hydraulic oil, Remote steering device, Rotating flashing beacon, Side shield easy adjust, Special painting, Working widths

Verifique o seu distribuidor local em nosso site www.dynapac.com.br

As informações acima se referem a uma descrição geral somente, não contém nenhum tipo de garantia. A Dynapac reserva-se o direito de alterar especificações sem prévio aviso. Fotos e ilustrações deste folheto podem conter itens opcionais.